

BP Solar's SX series provides cost-effective photovoltaic power for general use, operating DC loads directly or, in an inverter-equipped system, AC loads. With 75 watts of nominal maximum power, the SX 75TU is well-suited to traditional applications of photovoltaics such as telecommunications, remote villages and clinics, water pumping, and land-based aids to navigation. Its 36 enhanced-efficiency series-connected cells charge 12-volt batteries efficiently in virtually any climate.

## Proven Materials and Construction

BP Solar's quarter-century of field experience shows in every aspect of this module's construction and materials:

- 36 multicrystalline silicon solar cells in series, efficiency enhanced by improved cell coating;
- Cells are laminated between sheets of ethylene vinyl acetate (EVA) and high-transmissivity low-iron 3mm tempered glass;
- Frame strength exceeds requirements of certifying agencies.



## Clear Anodized Universal Frame

## High-Capacity Versatile Junction Box

The junction box is raintight (IP54 rated) and accepts PG13.5 or 1/2" nominal conduit or cable fittings. Its volume (411cc, 25 cubic inches) and 6-terminal connection block enable most system array connections (putting modules in series or parallel) to be made right in the junction box.

Options include:

- oversize terminal block which accepts conductors up to 25mm<sup>2</sup> (AWG #4); standard terminals accept up to 6mm<sup>2</sup> (AWG #10);
- Solarstate™ charge regulator.

## Quality and Safety

The SX 75TU is manufactured in BP Solar's ISO 9001-certified factories. The following qualifications have been granted:

- Listing by Underwriter's Laboratories for electrical and fire safety (Class C fire rating);
- Certification by TÜV Rheinland as Class II equipment;
- Approval by Factory Mutual Research for application in NEC Class 1, Division 2, Groups C & D hazardous locations;
- Certification of compliance with the requirements of IEC 61215, including:
  - repetitive cycling between -40°C and 85°C at 85% relative humidity;
  - simulated impact of 25mm (one-inch) hail at terminal velocity;
  - a "damp heat" test, consisting of 1000 hours of exposure to 85°C and 85% relative humidity;
  - a "hot-spot" test, which determines a module's ability to tolerate localized shadowing (which can cause reverse-biased operation and localized heating);
  - static loading, front and back, of 2400 pascals (50 psf); front loading (e.g. snow) of 5400 pascals (113 psf).

## Limited Warranties

- Power output for 25 years;
- Freedom from defects in materials and workmanship for 2 years.

See our website or your local representative for full terms of these warranties.



BP SX 75TU



## Electrical Characteristics<sup>1</sup>

	SX 75TU	SX 70TU <sup>4</sup>
Maximum power ( $P_{max}$ ) <sup>3</sup>	75W	70W
Voltage at $P_{max}$ ( $V_{mp}$ )	17.3V	17.0V
Current at $P_{max}$ ( $I_{mp}$ )	4.35A	4.11A
Warranted minimum $P_{max}$	70W	65W
Short-circuit current ( $I_{sc}$ )	4.75A	4.5A
Open-circuit voltage ( $V_{oc}$ )	21.8V	21.4V
Temperature coefficient of $I_{sc}$	(0.065±0.015)%/°C	
Temperature coefficient of voltage	-(80±10)mV/°C	
Temperature coefficient of power	-(0.5±0.05)%/°C	
NOCT <sup>2</sup>	47±2°C	
Maximum series fuse rating	20A	
Maximum system voltage	600V (U.S. NEC rating) 1000V (TÜV Rheinland rating)	

## Notes

1. These data represent the performance of typical BP SX 75TU and SX 70TU modules as measured at their output terminals, and do not include the effects of such additional equipment as diodes and cabling. The data are based on measurements made in accordance with ASTM E1036 corrected to SRC (Standard Reporting Conditions, also known as STC or Standard Test Conditions), which are:
  - illumination of 1 kW/m<sup>2</sup> (1 sun) at spectral distribution of AM 1.5 (ASTM E892 global spectral irradiance);
  - cell temperature of 25°C.
2. The cells in an illuminated module operate hotter than the ambient temperature. NOCT (Nominal Operating Cell Temperature) is an indicator of this temperature differential, and is the cell temperature under Standard Operating Conditions: ambient temperature of 20°C, solar irradiation of 0.8 kW/m<sup>2</sup>, and wind speed of 1m/s.
3. During the stabilization process which occurs during the first few months of deployment, module power may decrease approximately 3% from typical  $P_{max}$ .
4. The power of solar cells varies in the normal course of production; the SX 70TU is assembled using cells of slightly lower power than the SX 75TU.

## SX 75TU I-V Curves

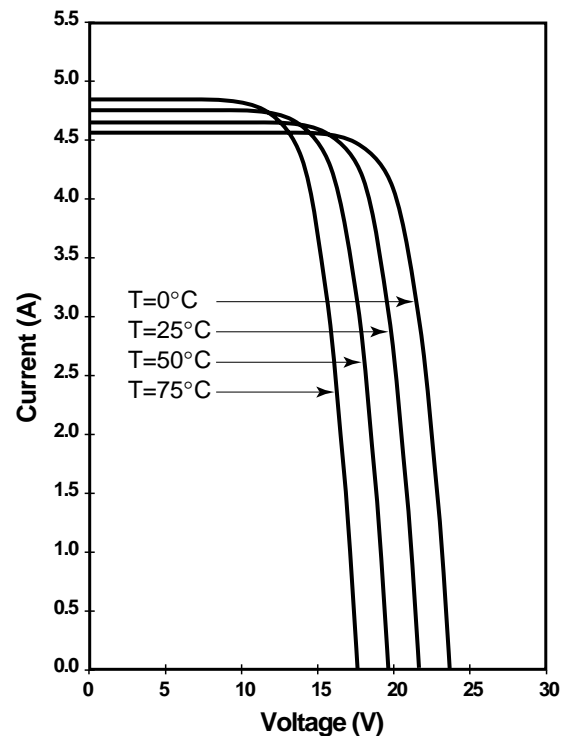

## Mechanical Characteristics

**Weight**  
 BP SX 75TU 7.7 kg (17 pounds)

**Dimensions**  
 Unbracketed dimensions are in millimeters.  
 Bracketed dimensions are in inches.  
 Overall tolerances  $\pm 3\text{mm}$  (1/8")

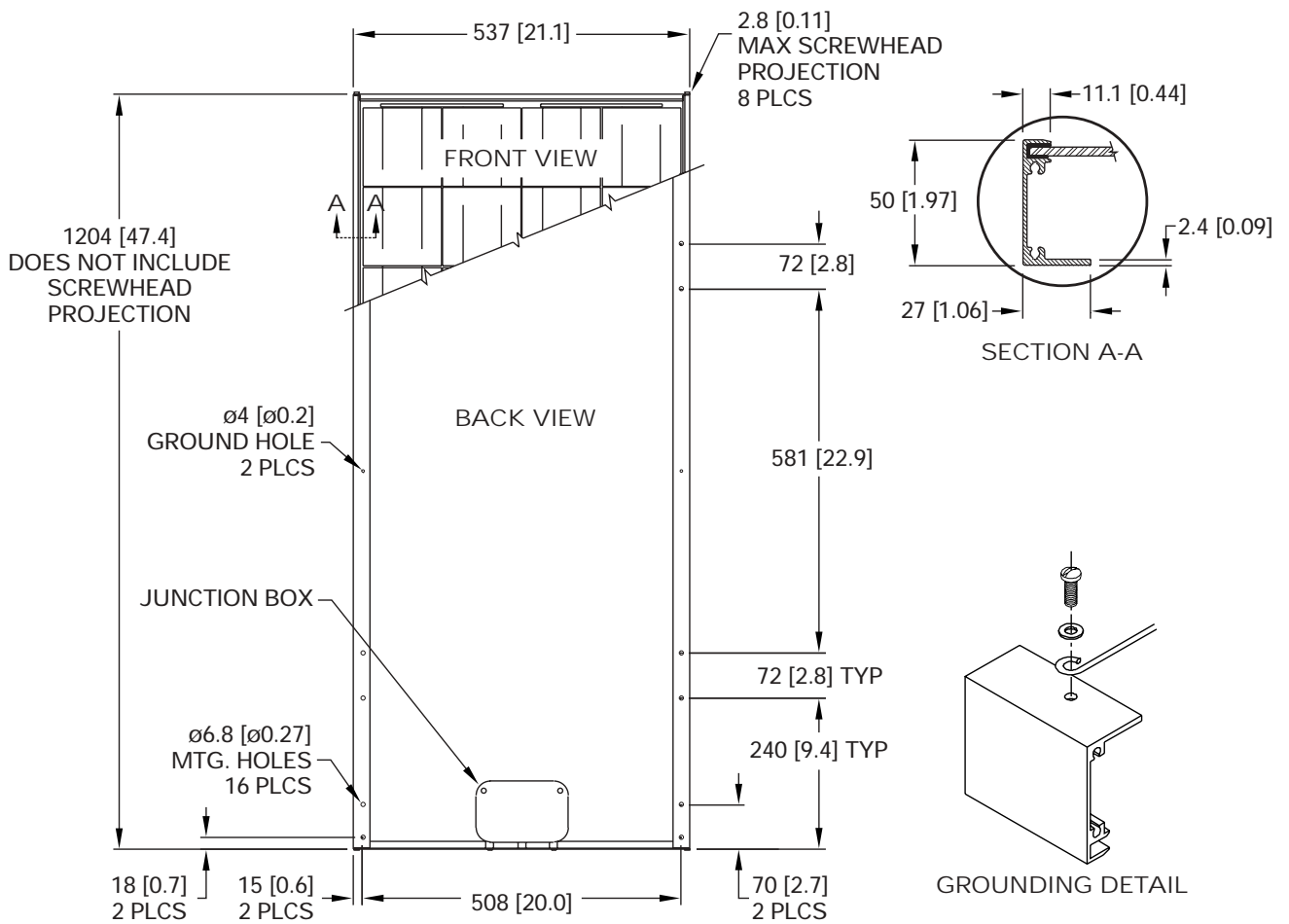

**BP SX 75TU**



bp solar

This publication summarizes product warranty and specifications, which are subject to change without notice and should not be used as the definitive source of information for final system design. Additional warranty and technical information may be found on our website [www.bpsolar.com](http://www.bpsolar.com) or may be obtained from your local representative.



Printed on recycled paper with vegetable based inks.